

Robotic Path-Planning for Computer-Aided Manufacturing



Technische Universität München



Fakultät für Informatik

Lehrstuhl für Echtzeitsysteme und Robotik

Background

Robots have yet to make an entrance into many industries (outside mass-manufacturing) and the service sector. A major hurdle to their widespread adoption is the complexity of their deployment, requiring costly specialists for every new task one wants to automate. We envision simple tools which help to choose the right robot and do the programming given a task and environment specification.

Description

One such tool we envision is based on the concept of covering regions of the workspace with tools held in the robot's end-effector, which we propose as a part of our benchmark suit for robotics cRoK (crok.cps.in.tum.de). A simple example would be painting a wall, where the robot has to cover a part of a plane with the tip of a brush, which could again be abstracted as a flat cuboid. More complex tasks can be found in welding or milling, where this task is also known as tool-path generation for computer-aided manufacturing (CAM); another example could be to finish the top surface of a skateboard with a cylindrical end-mill as shown in the image.

We envision that you develop a piece of software that lets the user interactively choose desired covering actions, defining the space to cover and the tool to cover this space with, and presenting possible solution paths. This may be done by interfacing with existing CAM software or through a simple self-developed GUI, which should be able to load mesh files, select parts of these to work on and present the solution path and robot moving along this path.

If all of this is working there are several possible extensions. For example, you can demonstrate your tool on a real robot or try to integrate more constraints on the tool path stemming from the used tools that may require certain cutting depths or processing speeds. Your own ideas are also welcome and probably integrable.

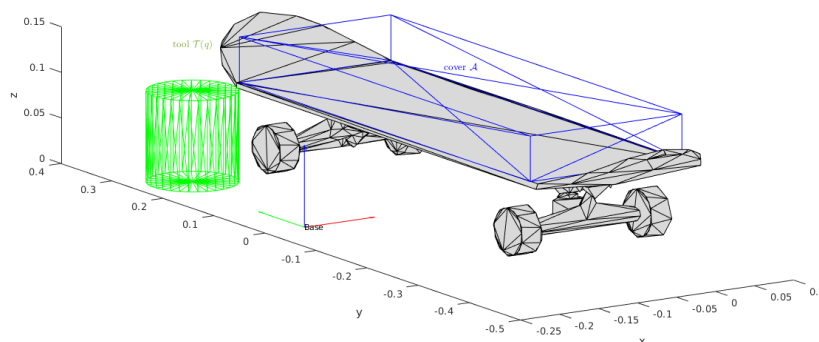

Finishing the surface of a skateboard with a cylindrical mill as a possible cover task.

Tasks

- Literature review on CAM in robotics
- Familiarize yourself with the modular robot toolbox
- Create a GUI to interactively select features of a part to cover, such as surfaces or edges
- Generate toolpaths and robot motion plans to fulfill the task and display both
- (Stretch Goals) Demonstrate abilities on a real robot, Integrate constraints on tool

Supervisor:

Prof. Dr.-Ing. Matthias Althoff

Advisor:

Matthias Mayer

Research project:

Modular Robotics

Type:

BA/MA

Research area:

Robotics, CAM

Programming language:

Python, (C++)

Required skills:

CAD / CAM, 3D modelling, or Motion Planning

Language:

English

Date of submission:

6. Mai 2022

For more information please contact us:

Phone: +49.89.289.18114

E-Mail: matthias.mayer@tum.de

Internet: www6.in.tum.de

References

- [1] M. Althoff, A. Giusti, S. B. Liu, and A. Pereira. Effortless creation of safe robots from modules through self-programming and self-verification. *Science Robotics*, 4(31):1–14, 2019.
- [2] M. Althoff M. Mayer. cRoK – A Composable Robotics Benchmark. In <https://arxiv.org/abs/2203.09337>, 2022.



Technische Universität München



Fakultät für Informatik

Lehrstuhl für Echtzeitsysteme und Robotik